



ArcelorMittal

Steel solutions for every style and taste

Your partner for domestic appliances



Contents

3
ArcelorMittal cares for your well-being



4
Estetic® Casa

5
Washing machines and dryers



6
Easyfilm®

7
Dishwashers



8
Ready-to-Paint HC220CA and HC260CA

9
Cooling systems



10
Enameling steels

11
Ovens, cookers and hoods



12
HC300EK enamelling steel

13
Bathtubs, showers and boilers



14
Easyfilm® Conductive

15
Television and hi-fi equipment

16
Co-engineering solutions from ArcelorMittal

Alusi®

Ready-to-Enamel

Aluzinc® HFX

Estetic® Casa Access

Estetic® Casa

Aluzinc®

Estetic® High Tech

Estetic® Casa Classic

Solfer® CA

Magnelis®

Estetic® Casa Visual

HX380LAD

Credits

Pictures:
page 4, 8, 10 : © Shutterstock – Kkulikov , Fotovika , ppart
page 6, 14: T. Dhaenens
page 12: Philippe Vandenameele
page 16: ArcelorMittal Global R&D

Copyright

All rights reserved. No part of this publication may be reproduced in any form or by any means whatsoever, without prior written permission from ArcelorMittal. Care has been taken to ensure that the information in this publication is accurate, but this information is not contractual. Therefore ArcelorMittal and any other ArcelorMittal Group company do not accept any liability for errors or omissions or any information that is found to be misleading. As this document may be subject to change at any time, please consult the latest information in the product document centre at industry.arcelormittal.com

xcellook®

Ready-to-Paint HC260CA

Solfer®

Estetic® Casa Protect

HC300EK

Ready-to-Paint HC220CA

Solfer®+

Easyfilm® Conductive

DCO7EK

Easyfilm®

Blued steel

ArcelorMittal cares for your well-being

ArcelorMittal is one of the world's leading providers of steel solutions for domestic appliances. Not only do our steels make day-to-day life easier, they also make it more elegant.

Our many decades of experience developing steel solutions for domestic appliances has taught us that different rooms in the house have very different and specific needs. ArcelorMittal's extensive catalogue offers steels which will meet any technical requirements including corrosion and chemical resistance, formability and mechanical properties.

We also have the modern look and colour palette today's discerning consumer demands. Let ArcelorMittal inspire and colour your interior with our wide range of pre-painted products.

We care for sustainability

ArcelorMittal is constantly developing new technologies which improve the sustainability of our products and business practices.

As a natural, permanent material which is 100% recyclable, steel is the ideal sustainable material. Steel is helping to meet the challenge of providing sustainable solutions which meet the needs of society today, and in the future.

ArcelorMittal is fully engaged in global efforts to reduce greenhouse gas emissions and mitigate their impact. We manage our production facilities in a responsible way and guarantee that our products fully respect the European directive on electric and electronic equipment (RoHS), and are free of harmful substances according to REACH regulations on the Registration, Evaluation, Authorisation and Restriction of Chemical Substances.

We also offer our customers ways to improve their carbon footprint. Using products from our Ready-to-Paint, Ready-to-Enamel, Easyfilm® or Estetic® Casa ranges results in energy savings and significantly lower water consumption during manufacturing.

Estetic® Casa

The pre-painted range developed specifically for domestic appliances.

With the launch of our Estetic® range in the '80s, ArcelorMittal became the first steelmaker to introduce organic coated pre-painted steels for domestic appliances. The use of organic coated steels has quickly become the standard in the appliance industry as they offer shorter production cycles, greener processes which require less water and energy, high quality finishes and cost reductions.

Recognising that original equipment manufacturers want to push the limits in the design of new appliances, ArcelorMittal has continued to develop its range. The latest addition to the Estetic® family is Estetic® Casa, a selection of four products with the gloss, surface aspects and modern finishes appliance makers are looking for today. Not only does Estetic® Casa offer superior performance and aesthetics, it is a tailor-made solution which can be adapted to any type of appliance.

Through tests with our customers, we have proved that ArcelorMittal's organic coated steels meet the technical requirements of the manufacturing process. They also preserve the appliance's quality over its entire life cycle, providing reassurance to both the appliance maker and the end-user.

Steel	Advantages	Technical characteristics
Estetic® Casa Access	Most cost-effective solution for quality built-in appliances.	Salt-spray test (SST): 192 hours T-bend crack: 2 T Gloss Units (GU): 40-80
Estetic® Casa Classic	The reference product for applications where standard corrosion protection is required.	SST: 240 h T-bend crack: 2 T GU: 30-90
Estetic® Casa Protect	Offers improved corrosion protection and detergent resistance with maximum flexibility.	SST: 360 h T-bend crack: 1T GU: 30-90
Estetic® Casa Visual	Combines protection, flexibility, and hardness with aesthetics. Opens new creativity options as aspect, gloss, and finish can be controlled.	SST: 360 h T-bend crack: 0.5 to 1 T GU: from 5 to 100

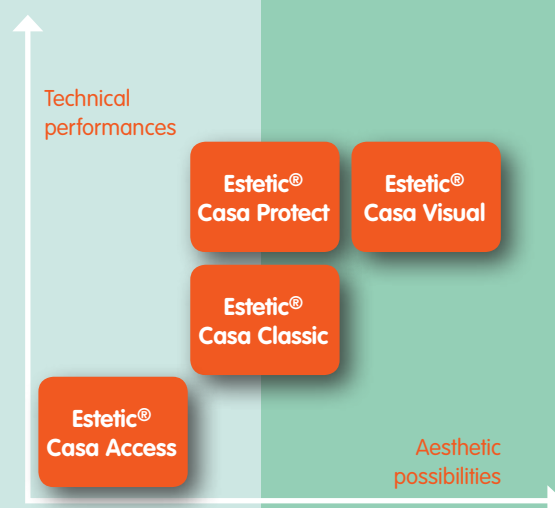

Washing machines and dryers

Appealing aesthetics combined with higher structural performances thanks to our high strength and pre-painted steels.

Our Estetic® Casa products provide aesthetics for the cabinet and protection against detergents.

Estetic® Casa Protect

- Very flexible paint system which encourages creative designs while providing protection against detergents and cleaning products.

Estetic® Casa Visual

- Exclusive paint system which provides optimum resistance to chemical agents and detergents, combined with a beautiful aspect.

High strength steels improve the structural performance of washing machines and dryers. This can lead to better performance and cost reductions as the gauge of the steel can be optimised. ArcelorMittal's offer includes:

- High Strength Low Alloy (HSLA) HX380LAD and HX420LAD grades up to 500 MPa. Used for structural parts.
- Interstitial Free High Strength steels (IFHS) up to 300 MPa with good formability. Ideal for side and front panels.

Dryer drum cost advantages with Aluzinc® coating

Aluzinc®

- A zinc-aluminium coating offering high corrosion and heat resistance and shiny aesthetics at a competitive price.

Aluzinc® HFX

- High Formability Extended (HFX) allows severe deformations while providing the intrinsic qualities of Aluzinc®.

Easyfilm®

A thin and transparent organic coating which can be applied to metallic-coated steels.

Easyfilm® offers:

- Easier forming and eliminates the need for lubricating oils and degreasing
- Corrosion protection during storage and transport
- Fingerprint resistance for non-painted parts
- Direct-on painting without pre-treatment
- Freedom from chromates and heavy metals.

Easyfilm® complies with the most recent European directives on consumer and environmental protection.

Typical applications for Easyfilm® include:

- Back panels: Ready to assemble after stamping
- Visible parts: Ready to be painted without surface treatment, immediately after deep drawing.

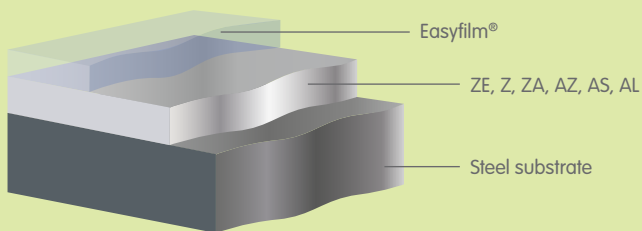

ZE: ELO (electro Zn), Z: hot dip galvanised Zn, ZA: Galfan (Zn - 5% Al), AZ: Aluzinc (Zn - 55% Al), AS: Alusi (Al - 10% Si), AL: Alupur (Al)

Properties	Easyfilm®
Temporary protection	+
Fingerprint resistance	⊕
Formability	⊕
Paintability	⊕
Spot-welding resistance	+
Environmentally friendly	⊕

+ Very good ⊕ Excellent



Dishwashers

ArcelorMittal coated steels offer dishwasher buyers creative aesthetics and protection against detergents.

Estetic® Casa Protect

- Very flexible paint system which allows creative designs while protecting the cabinet against daily cleaning with detergents.

Estetic® Casa Visual

- Exclusive paint system which provides optimum resistance to chemical agents and detergents.

Longer durability for hinges

- Magnelis® provides the best corrosion protection and surface resistance against long-term wear. It also self-heals on cut edges. Magnelis® is a cost-effective alternative to post-galvanisation for appliance components such as hinges.

Cost savings for freestanding dishwashers

- Combining hot dip galvanisation with Easyfilm® can reduce the cost of non-visible panels.

Corrosion resistance and very high formability for dishwasher tanks

- Aluzinc® HFX combines the excellent corrosion resistance of Aluzinc® with high formability. Using Aluzinc® HFX, extremely complex tank designs can be realised.

Ready-to-Paint for grades HC220CA and HC260CA

Cold rolled steel grades with temporary corrosion protection and excellent paint adherence.

The external panels of appliances are exposed to harsh conditions in day-to-day life.

ArcelorMittal's Ready-to-Paint for steel grades HC220CA and HC260CA are the perfect solution.

Both cold rolled steel grades have high mechanical properties together with improved surface flatness and cleanliness. This guarantees a very robust process and that the perfect shapes drawn by the designer will be preserved throughout the appliance's lifecycle.

Ready-to-Paint is an organo-metallic coating which can be painted without surface treatments such as degreasing, phosphating or passivating.

It offers:

- Excellent paint adherence and corrosion resistance
- Temporary corrosion protection during transport, storage and manufacturing.

Cooling systems

Refrigerators and freezers require easy-to-clean and durable high-end aesthetics.

Cost-effective and robust appliance cabinets can be produced with:

- HC220CA and HC260CA grades, which ensure a perfect result during manufacturing and excellent quality of the final product. Those steel grades also enable manufacturers to optimise the gauge used for the cabinet which reduces costs.
- Steels finished with ArcelorMittal's Ready-to-Paint organic coating, which can be directly painted without the need for additional surface treatments.

ArcelorMittal's pre-painted steels offer aesthetics and protection against detergents.

Estetic® Casa Classic

- The reference pre-painted steel for refrigerators.

Estetic® Casa Visual

- An exclusive paint system which provides optimum resistance to chemical agents and detergents. Enables manufacturers to produce creative designs with metallic or solid colours and surfaces ranging from glossy to deep matt.

xcelllook®

- The look of stainless at a cost-effective price.
- Brushed metallic coated steel with a high end varnish.

Compressors: keeping things cool.

- Cooling is expensive! Using ArcelorMittal's low loss electrical steel grades increases the efficiency of the compressor and reduces energy consumption in refrigerators and freezers.
- Our hot rolled deep drawing grades (for example, DD11 or DD14) create a smooth surface for the compressor's outer box.
- High strength steels HX380LAD and HX420LAD are key high strength steels which guarantee that compressor supports can carry the load of the compressors in all circumstances.

Enamelling steels

ArcelorMittal offers the most exhaustive range of cold rolled enamelling steels for appliances.

Our range of enamelling steels goes far beyond the requirements of the European norm EN 10209. As well as simplifying manufacturing processes, ArcelorMittal's enamelling steels offer high-end quality and trendy designs for consumers.

At the same time, they respect the environment.

Our range includes:

- **DC07EK:** enables manufacturers to simplify their processes. The steel's deep drawing properties allow appliance designers to realise trendy and refined designs with thinner gauges.
- **Solfer[®], Solfer[®]+ and Solfer[®] CA:** those products are used to produce parts with guaranteed quality and a very clean surface. Solfer[®] and Solfer[®]+ also limit deformation during pyrolysis (self-cleaning) cycles in ovens and provides good impact resistance.
- **Ready-to-Enamel (R2E):** a cost-effective solution for appliance parts. The enamel bonding is environmentally friendly and makes transformation of the parts simple.

Our **Ready-to-Enamel** organic coating binder is applied to enamelling steels at the ratio of approximately one gram per square metre (~1 g/m²). The dry organic coating is applied to:

- Ensure temporary corrosion protection
- Improve formability considerably without the need for a lubricant
- Enable enamelling without surface treatment or degreasing.

Ready-to-Enamel can be applied to any enamelling steel in the ArcelorMittal range.

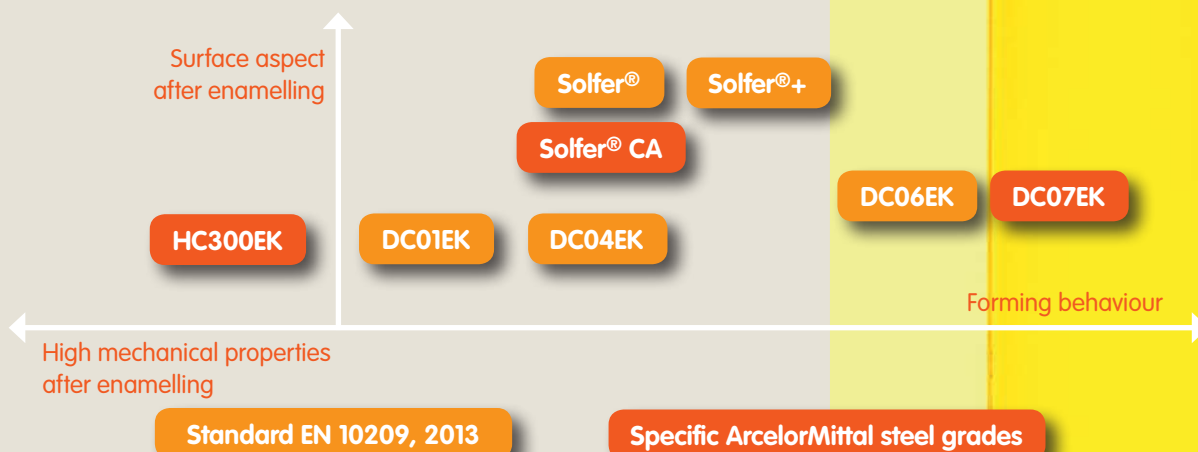

Ovens, cookers and hoods

Simplifying the appliance manufacturing process leads to energy savings.

Cost-effective solutions for the external wrapper of ovens:

- Our galvanised high strength steel grade HX380LAD allows manufacturers to reduce the thickness of the oven wrapper. ArcelorMittal's Easyfilm® thin organic coating will ease deep drawing operations and eliminate the need for degreasing.

Steels suitable for food contact applications such as baking trays and accessories:

- Alusi® is a steel that resists oxidation at temperatures up to 650°C without distortion. Even at high temperature, the thermal and light reflectivity of Alusi® reaches 80%.
- Blued steel is a cost-effective cold rolled steel which protects cooking accessories against corrosion.

Achieve extremely sophisticated oven cavity designs while simplifying the manufacturing process:

- ArcelorMittal's DCO7EK enamelling steel grade offers the highest quality. Adding our Ready-to-Enamel coating improves part formability significantly and simplifies the fabrication process as no degreasing is necessary.

Quality performance for oven front door frames:

- Solfer® allows manufacturers to achieve very high quality surfaces on extreme drawing parts. Dimensional stability is also preserved. Solfer® is perfect for both direct-on-white and conventional enamelling processes.

HC300EK enamelling steel

The best structural cold rolled steel for enamelling with guaranteed minimum yield strength after firing.

HC300EK can be used for both one- and two-sided enamelling. It is particularly suitable for boiler applications where it can substitute hot rolled grades.

HC300EK offers multiple benefits for boiler and appliance makers including:

- Material savings of at least 10% thanks to possible thickness reductions
- Wider dimensional possibilities (lower thickness, wider coils) lead to productivity increases and stock optimisation
- Simplification of surface treatments. For example, shot blasting can be avoided depending on enamelling condition.
- Eliminates degreasing costs and the need for pickled steel.

	R_e (MPa) after firing	R_m (MPa) after firing	A (%)
HC300EK	300/420	360/500	> 25



Bathtubs, showers and boilers

Timeless aesthetics for bathtubs.

Guaranteed mechanical properties for boilers.

Design freedom for bathtubs with ArcelorMittal's DC07EK enamelled steel grade:

- DC07EK presents optimised mechanical properties for very difficult stamping, such as bathtubs or shower trays presenting angular shape and small radii.

Thickness reduction for boilers:

- ArcelorMittal's HC300EK enamelling steel grade comes with mechanical property guarantees after enamelling.

Achieving thermal isolation while maintaining a constant temperature for wall-mounted boilers:

- Alusi[®] is a metallic coating with a high aluminium content (90%). It offers good resistance to oxidation at high temperatures (up to 650°C) while maintaining high reflectivity and energy efficiency.

Aesthetic solution for boilers and wall-mounted water heaters:

- Estetic[®] Casa Classic is a perfect solution for the external envelope of boilers and wall-mounted heaters. This high quality pre-painted steel ensures the product will complement almost any interior design.

Easyfilm[®] Conductive

A polymer layer, totally free of chromium, for excellent processing and electrical conductivity.

A polymer layer which is totally free of chromium, Easyfilm[®] Conductive is applied to metallic coated steel in a 1.5 to 2 μm layer.

The coating provides:

- Excellent conductivity
- Improved deep drawing
- Ability to eliminate degreasing
- Fingerprint resistance
- Very good chemical resistance.

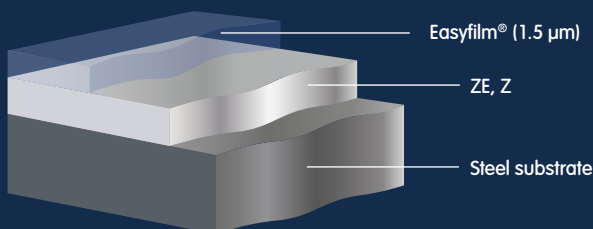

ZE: ELO (electro Zn), Z: hot dip galvanised Zn

Television and hi-fi equipment

Solutions for high-end aesthetics with conductive properties.

Improving the deep drawing and conductivity properties of panels for television, satellite receivers and other electrical equipments:

- Easyfilm® Conductive has excellent deep drawing properties and good conductivity.

Robust and elegant, dark-black paint system for the appliance's envelope:

- Estetic® High Tech is a 25 µm paint system which is scratch resistant and flexible. The finish achieved is a slightly grained, matt deep-black colour.



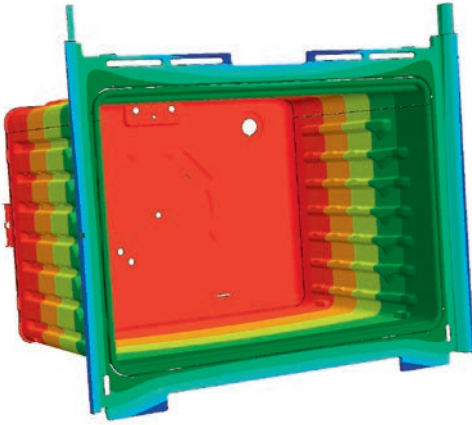

Numerical simulation of the thermal dilatation of an oven cavity

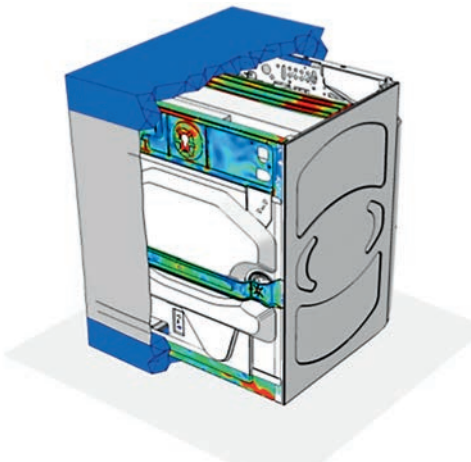

Simulation of a drop-test on a washing machine



Simulation of the deep drawing process: washing machine front panel

ArcelorMittal co-engineering solutions

ArcelorMittal helps customers to optimise their processes, reduce costs and improve results, thanks to an innovative co-engineering approach. Together with the customer, our first-class technical support team works to solve problems, as well as co-engineering and co-designing new applications.

Our co-engineering team includes researchers and technicians with a strong mechanical-design background. They focus on reducing the total cost of ownership through intelligent design. Their design solutions are typically lighter, stronger, more sustainable, and are less labour-intensive.

ArcelorMittal assists our customers through all the stages of product development, up to and including serial production. Our co-engineering support can include design optimisation, assistance with deep drawing processes, drop tests and fatigue analysis, warping analysis, vibro-acoustic optimisation, and support for prototype manufacturing.

ArcelorMittal's support for deep drawing processes includes:

- Optimisation of the process using finite element simulations
- Definition of minimal mechanical properties and thicknesses for successful production
- Selection of the most suitable steel grade for each application
- Deformation analysis of stamped parts to validate the theoretical analysis
- Technical support in production.

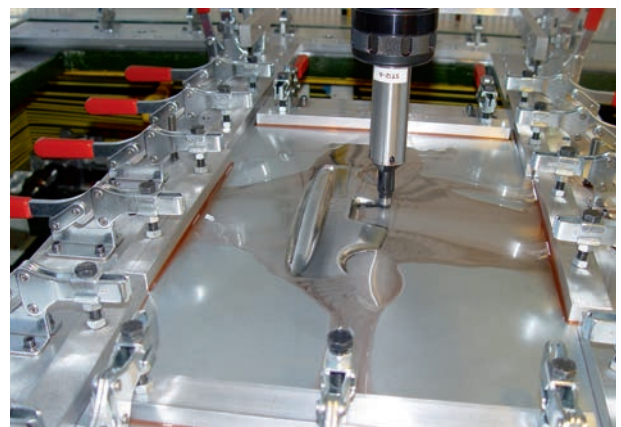

Incremental fast prototyping tool

